

unosand

**Sanding and Denibbing Solutions
for Flat, Profiled and
Moulded Components**



Sanding strip and hub price list.

Sanding Strips - Prices £GB per linear meter.

UNOSANDING STRIPS (single row brush)

Single Side Abrasive		Double Side Abrasive		Overall Height
Model	Price L/M	Model	Price L/M	
P22	£16.00	P22/2	£22.40	42mm
P32	£16.00	P32/2	£22.40	52mm
P42	£16.00	P42/2	£22.40	62mm
P52	£16.00	P52/2	£22.40	72mm
P67	£16.00	P67/2	£22.40	87mm
P87	£18.00	P87/2	£25.20	107mm

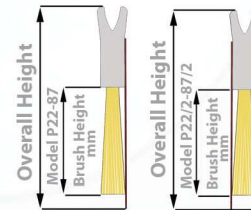

HEAVY DUTY UNOSANDING STRIPS (double row brush)

P32H	£20.00	P32H/2	£28.00	52mm
P42H	£20.00	P42H/2	£28.00	62mm
P52H	£24.00	P52H/2	£33.60	72mm
P67H	£24.00	P67H/2	£33.60	87mm

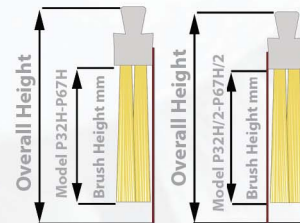

ABRASIVES

Aluminium oxide (Prefix A + grit size)

60 80 100 120 150 180 220 240 280 320 400 600

Silicon Carbide (Prefix S + grit size)

24 80 100 120 150 180 220 240 320 400

Plus 50% Ex Stock

ABRASIVE BLADES

03mm Wide 04mm Wide 07mm Wide 20mm Wide 00mm (Solid)

LIGHT SUPPORT BRUSHES - Single Row

Model	£ Price Per L/M	Overall Height
S32L	£9.00	47mm
S42L	£9.00	57mm
S52L	£9.00	67mm

HEAVY SUPPORT BRUSHES - Double Row

S32H	£15.00	47mm
S42H	£16.00	57mm

LARGER HUBS

Model	Price L/M
AQW	£2.50

Hub Adapters
(Single row and light support brushes only)

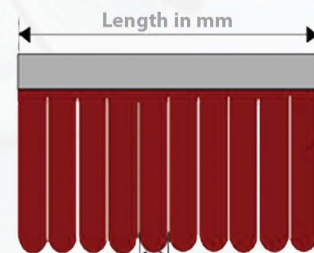

Available with 03/04/07/20mm approx blades
00mm (solid blade)

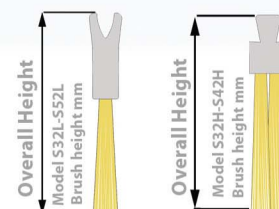

Light Support
Brushes

Heavy Support
Brushes

Ordering Examples

Model denotes brush Height

Qty	Model	Length in mm	Abrasive/grit size	Price each
Any	P42/2	0100	A 220/07 + A280/04	£2.24
Any	P42	0140	S 320/20	£2.24
Any	S32L	1350	Support Brush	£12.15
Any	P67/2	1000	S 320/03	£22.40
Any	AQW	1400	Adapter	£3.50

Maximum length of strip: 2000mm

N.B. Unosanding strips are designed to fit into Unosanding Hubs (See separate page)

Unosanding strips will fit directly into many other keyways from other manufacturers. Keyways vary in dimensions.

If in doubt please sample before ordering.

Prices ex-works + VAT - Subject to our terms and conditions of sale

Unosand POM Hubs

Sanding hubs are available with six different diameters and six standard dimensions, as well as by the meter for custom fitting.

Standard hubs will be delivered with two 5mm end caps adding 10mm to the overall length of the complete unit. Please advise bore dimension.

When ordering with one split end cap and one standard end cap, quoted price includes an allowance for the standard end cap no longer required.

One end cap and one split end cap will add 18mm to the overall length of the complete unit.

Please advise on bore dimension.

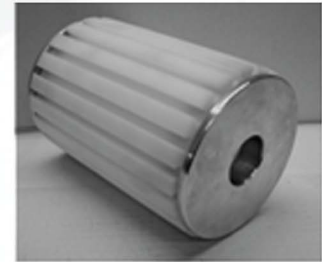

Hub showing standard end cap

Diameter (mm)	80	105	125	150	180	280
No. of keyways	16	20	24	30	36	54
Length (mm) excluding end plates						
75	£92.00	£107.00	£119.00	£130.00	£135.00	-
140	£104.00	£127.00	£141.00	£149.00	£154.00	£331.00
150	£106.00	£131.00	£145.00	£157.00	£162.00	£350.00
200	£131.00	£145.00	£162.00	£191.00	£196.00	£406.00
280	£146.00	£175.00	£195.00	£228.00	£235.00	£454.00
300	£154.00	£183.00	£204.00	£238.00	£246.00	£477.00
>300mm Price/meter	-	£588.00	£654.00	£877.00	£907.00	£1330.00
End Caps 2 x 5 mm	inc.	inc.	inc.	inc.	inc.	inc.
Straight Keyways	✓	✓	✓	✓	✓	✓
Spiral Keyways	-	-	-	-	✓	✓
Split end caps 1 x 13mm	£54.00	£58.00	£62.00	£71.00	£73.00	£135.00



Hub showing split end cap

The Hubs are manufactured from POM, lightweight and chemical resistant. The end caps are ALUMINIUM for strength and stability.

Split end caps allow for easy access to the sanding strips without the need to remove the hub from the shaft.

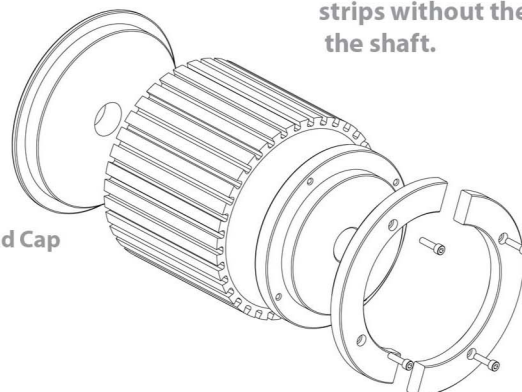

Standard End Cap

Split End Cap

Unosanding Hubs and strips will integrate into most sanding systems.

Email, fax or telephone for technical advice

Prices in GB Pounds, ex-works + VAT - Subject to our terms and conditions of sale

unosand

Applications

Visit www.unosand.com for more examples.

Sand and denib components individually, in pairs or stacks. Stack sanding vastly increases productivity and allows internal sharp edges to be kept intact.



Achieve excellent results when denibbing paint and lacquer with Unosand sanding strips. Select silicon carbide abrasive strips for the best finish.

Unosand strips will sand every detail of your mouldings whether simple or intricate. Optimize performance by mixing different width strips e.g. 4mm and 7mm.

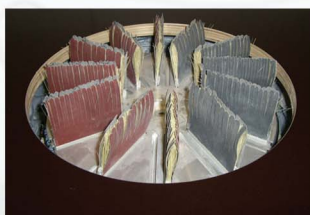

Unosand double sided abrasive strips allow you to sand and denib on the same machine with the flick of a switch without having to change abrasive strips.

Unosand strips are ideal for edge sanding. Use short brushes with high pressure and aluminium oxide abrasive.

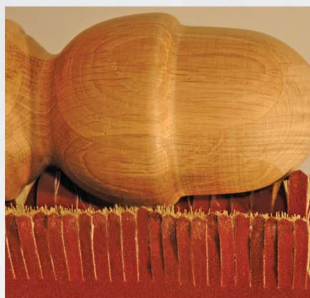

Unosand strips will reach into all kinds of turned components. Select longer aluminium oxide abrasives with double row brushes with a combination of narrow blades.

Unosand strips are ideal for removing the fine marks left by belt sanding operations. Wider blades should be used on softwood so that the heartwood is not abraded more than the growth rings.



Always pre-sand (intermediate sand) before applying finishes such as paint or lacquer. Use multi directional heads to sand fibers in all directions.

Unosand sanding strips will fit into many different machines. Low cost adapters are available to convert larger keyways. The unique design clears the keyway allowing easy fitting. Call now or visit www.unosand.com for your free sample.



Unosand UK Ltd. Unit 10 Farfield Industrial Estate
Hillfoot Road, Sheffield S3 8AA, England
Tel: +44 (0) 114 2758811 Fax: +44 (0) 114 2750522 sales@unosand.com

www.unosand.com